

NEW STRONGER TORQUE

XL-MHD



The **XL-MHD** series delivers the deepest depth and the highest torque. The truck- or track-mounted XL-MHD drills up to 12 feet in diameter. Overall, the XL-MHD offers an excellent combination of power, dependability, versatility, and efficiency on even the most demanding jobs.

Whether you prefer square or round Kelly bars, the XL-MHD is available in multiple mast-height configurations. The XL-MHD does not require any assembly for track units, and truck units are mounted on a conventional truck chassis permitting quick mobilization saving valuable time and expense.



XL-MHD SPECIFICATIONS	STANDARD	METRIC
Max Pile Depth	50' - 120'	15.24 - 36.58m
Max Pile Diameter	12'	2.66m
Max Torque	90,000 ft./lbs.	122.02kNm
Max RPM (low)	18 rpm	18 rpm
Max RPM (mid)	45 rpm	45 rpm
Spin Off Speed	140 rpm	140 rpm
Crowd	62,832 lbs.	280 kN
Main Winch	23,000 lbs.	102.31 kN
Auxiliary Winch	12,000 lbs.	53.38 kN
Fuel Tank	70 Gallons	265 Liters
Engine - John Deere 6068	185 HP	185 HP

KELLY BAR TYPE	DRILL DEPTH*	WORK HEIGHT
7" x 9.25" x 12.5" Round	50'	30'
4" x 6" x 8" x 10" Square	70'	30'
4" x 6" x 8" x 10" Square	120'	47' 6"



Truck-Mounted Dimensions:

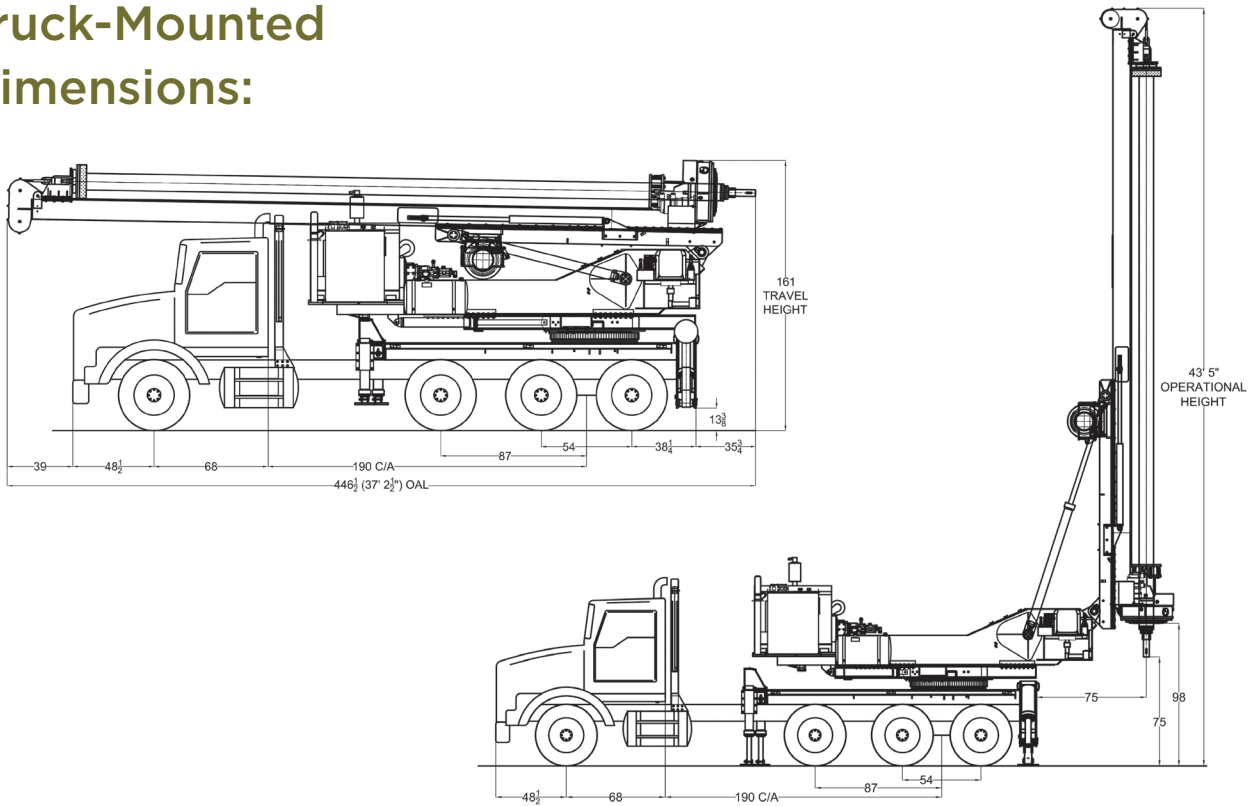

XL-MHD

“We consider the overall cost of ownership not just the purchase price when we analyze what brands we go with. When you take into account the increased uptime, production, and high resale values, *Spiradrill brings our company a lot of value.*”

-Scott W.
Powersecure

Crawler-Mounted Dimensions:

See all models
on our website:

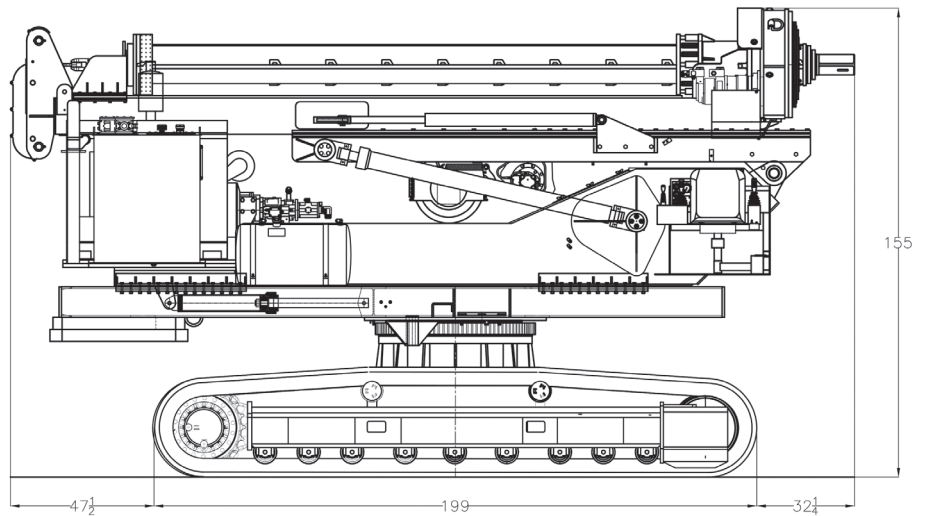

112 FM 153, Smithville, TX 78612
(512) 237-4140 | 800-380-0133
www.spiradrill.net | email: sales@spiradrill.net