

**NEW STRONGER TORQUE**

**LHD**



The **LHD series** is the premier drill in its class. The unique crowd design allows the mast, winch, Kelly, and rotary gearbox to feed the drill tool simultaneously, making it easier, safer, and more efficient. The LHD is available in several different models, including a “Short Mast” road-legal truck-mounted unit, and a track-mounted unit. This versatile unit has the increased capacity and ability to drill larger diameter holes in even the toughest soil conditions.

Whether you prefer square or round Kelly bars, our multiple mast-height configurations on the LHD will give you the confidence you need for every job.



*Want to take your LHD drill where other vehicles can't reach? Put it on a PowerBully. Ask us for details.*

LHD SPECIFICATIONS	STANDARD	METRIC	KELLY BAR TYPE	DRILL DEPTH*	WORK HEIGHT
Max Pile Depth	22' - 70'	6.71 - 21.32m	4.5" x 7.25" Round	22'	25'
Max Pile Diameter	6'	1.82m	3.5" x 5" x 7" Square	35'	25'
Max Torque	40,000 ft./lbs.	54.23kNm	3.5" x 5" x 7" Square	50'	30'
Max RPM (low)	22 rpm	22 rpm	4.5" x 7.25" Round	50'	39' 6"
Max RPM (mid)	56 rpm	56 rpm	5" x 7" Square	50'	39' 6"
Spin Off Speed	140 rpm	140 rpm	3.5" x 5" x 7" Square	70'	39' 6"
Crowd	48,100 lbs.	214 kN			
Main Winch	12,000 lbs.	53.38 kN			
Auxiliary Winch	8,000 lbs.	35.58 kN			
Fuel Tank	50 gallons	189 liters			
Engine - John Deere 4045	173 HP	173 HP			



# Truck-Mounted Dimensions:

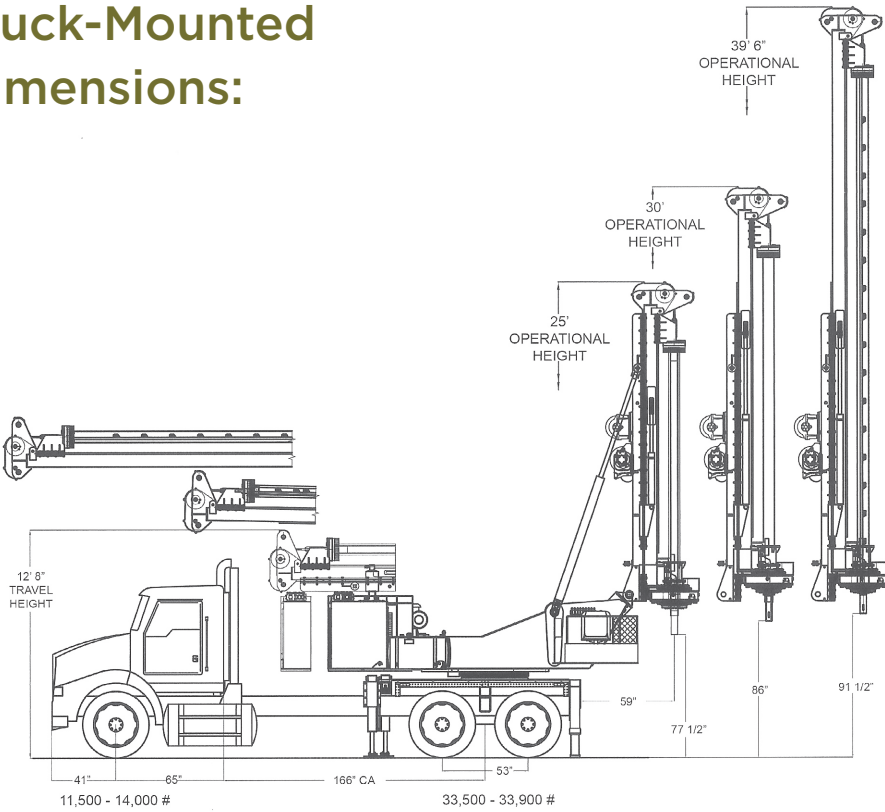

See all models  
on our website:



LHD

“In most construction projects, jobs are performed under fixed-price estimates, so productivity is what makes your money. *Spiradrill rigs have provided me with way more productivity than any other hole digger we’ve used.*”

-Jimmy Webb, Llano Auger Service

# Crawler-Mounted Dimensions:

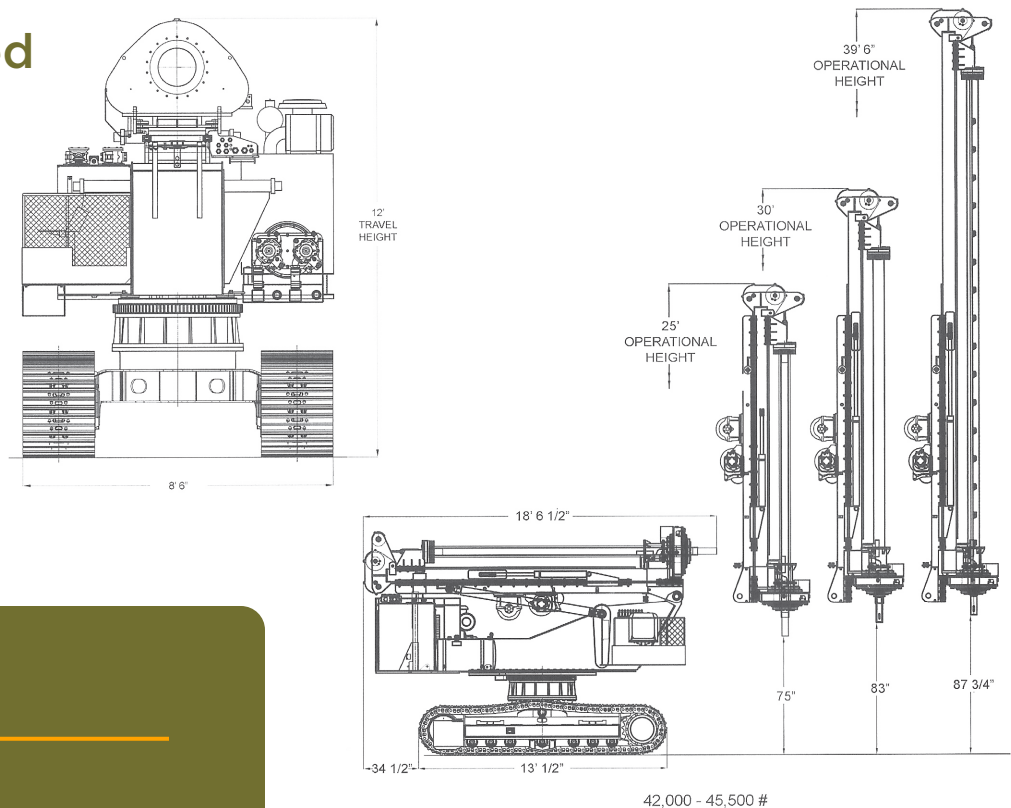

112 FM 153, Smithville, TX 78612  
(512) 237-4140 | 800-380-0133  
www.spiradrill.net | email: sales@spiradrill.net